

DEBURRING & FINISHING

# SUTTON CENTRI-FLO TORNADO

The Sutton Centri-Flo machines are specialized heavy-duty spindle-finishing machines designed for high production environments. These large part deburring systems are primarily designed to finish parts such as turbine disks, blades, blisks, and impellers - with the capability of finishing many other types of parts. These machines are able to finish parts much faster than hand finishing.

**Ideal for finishing:**

- Large parts
- Parts with tight tolerances
- Parts with hard-to-reach areas
- Parts with long finishing times
- Parts that can't be finished by hand
- Where part consistency is important

Model: CFT 3000



Inquire Today:  
Carlson Fabrication Solutions

adam@carlsonfab.com  
(781) 937-9599  
www.carlsonfab.com



ALMCO offers 3 models of Sutton Centri-Flo machines, the CF Series, CFT Series, and CFA Series. These large part deburring systems differ from each other based on the movement of the tub and spindle.

The Sutton Centri-Flo Tornado (CFT Series) finishes parts primarily through the movement of the spindle. In the CFT Series, the spindle does all the work, and the part rotates at a high speed and at various angles within the tub of vibrating media. In addition to having the ability to position the spindle in various angles within the tub, it also can swing back and forth through the media as the spindle rotates - similar to the motion of a pendulum. It also has the ability to stop mid-cycle and change rotation direction. This motion allows the media and processing liquid to flow through the part's features to deburr the edges and blend surfaces.

**Standard Features:**

- PLC touch screen controls
- Automatic lubrication system
- Interlocking safety doors
- Flowmeter

**Options:**

- Compound dispensing system
- Hour meter
- Operator work platform
- Tooling
- UL 508A electrical controls



PLC Touch Screen Controls

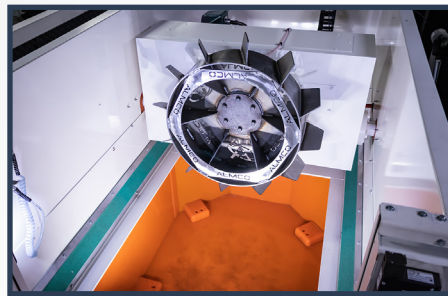

Top View of Sutton CFT Series

**Spindle Positioning**

- Stationary
- Oscillating

**Equipment Movement:**

**Tub:** Vibrates. No rotation.

**Spindle:** Rotates and moves in various angles and directions.

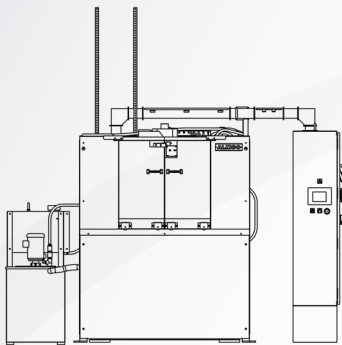

CFT-2500

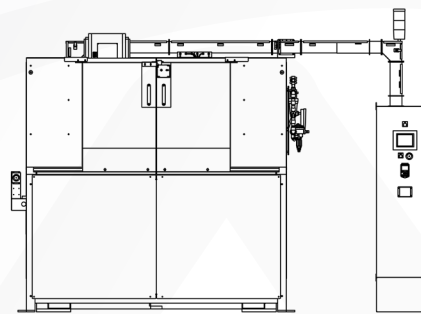

CFT-3000

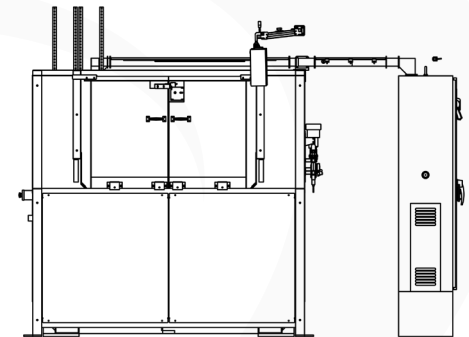

CFT-4000

**Specifications**

Model	Spindle RPM	Max Part Diameter	Drive HP	Overall Dimensions (In)
CFT-2000	200-1200	18	30	65 x 90 x 108
CFT-2500	125-750	30	30	75 x 112 x 90
CFT-3000	125-750	40	50	105 x 135 x 90
CFT-4000	125-750	40	75	105 x 135 x 108
CFT-6000	30-250	55	125	120 x 190 x 142



VISIT US ON

